

HIGHLIGHTS

- Reclaim fiber with DWDM technology
- Dramatic increase in forward transmission bandwidth
- Eight wavelength solution
- Compliment to node segmentation architectures
- 1GHz RF bandwidth
- Fully compatible with existing PWRLink product line
- Up to 30km
- Analog and digital narrowcasting
- Advanced predistortion circuitry and algorithm for both CTB and CSO provide state-of-the-art distortion cancellation over a wide temperature range
- Integrated element management with SNMP compatibility
- Microprocessor control of all key parameters provides consistent and optimum product performance and monitoring

Harmonic's PWRLink™ family of 1310 nm DWDM DFB laser transmitter modules is designed for advanced broadband networks. PWRLink transmitters can operate alone in local distribution or narrowcasting applications and in combination with Harmonic's externally modulated transmitter family for complete system solutions.

The DWDM PWL4112S-DXX transmitter modules are very compact with 10 transmitter modules fitting into a single three rack-unit high HLP 4200 platform via the HMC 4001 module carrier adapter. They are intelligent and can be set up in a matter of minutes by means of the user-friendly interface. Configuration can be done in three different ways: via the HLP 4200WD platform front panel menu, the RF adjustment on the module front panel or the NETWatch™ Element Management System.

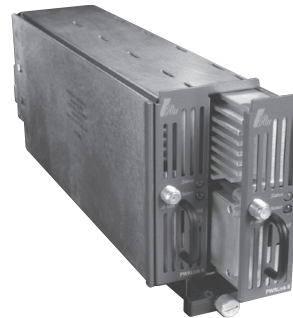

Harmonic DWDM PWL4112S-DXX transmitters are designed to multiplex up to eight wavelengths over a single fiber. This solution increases the downstream bandwidth without the need for more fibers.

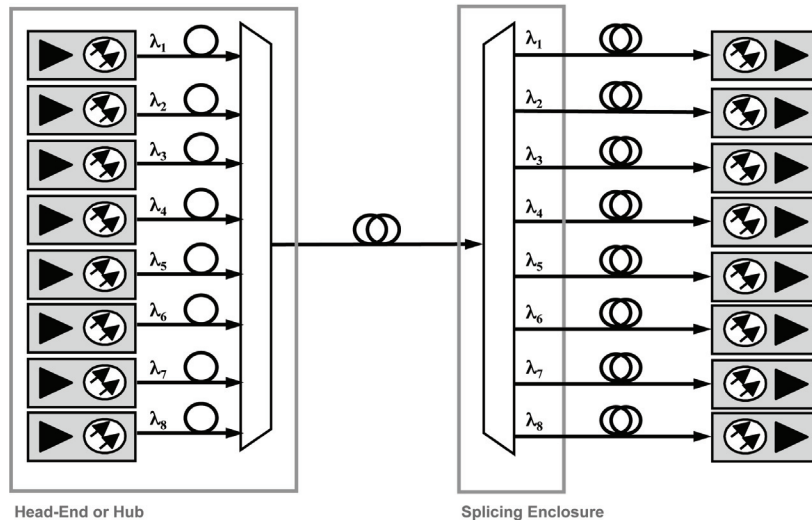

Typical Application

MODELS AVAILABLE

PWL4112S-DXX-ZZ

xx = Channel number (01, 02, 03, 04, 05, 06, 07, or 08)

zz = Connector Type (AS, AF, or AE)

LINK PERFORMANCE

Link Distance	<10km with eight wavelengths
Carrier-to-noise (CNR)	> 51 dB typical
Carrier-to-CSO	> 60 dB typical
Carrier-to-CTB	> 69 dB typical

Link Distance	<15km with six wavelengths
Carrier-to-noise (CNR)	> 51 dB typical
Carrier-to-CSO	> 60 dB typical
Carrier-to-CTB	> 69 dB typical

Link Distance	<20km with four wavelengths
Carrier-to-noise (CNR)	> 51 dB typical
Carrier-to-CSO	> 60 dB typical
Carrier-to-CTB	> 69 dB typical

Link Distance	<30km with two wavelengths
Carrier-to-noise (CNR)	> 50 dB typical
Carrier-to-CSO	> 60 dB typical
Carrier-to-CTB	> 69 dB typical

See notes 1 through 9.

OPTICAL OUTPUT

Model	Optical Power
PWL 4112S-DXX	12 ± 0.5dBm ¹⁰

RF INPUT

Input Level Range per Unmodulated Analog Channel	15 dBmV to 22dBmV
Operational Bandwidth	50 to 1003 MHz
Frequency Response	<1 dB peak-to-valley typ.
RF Attenuator Adjustment Range	10 dB
Impedance	75 Ω
Return Loss	> 16 dB (50 - 870MHz) > 14 dB (870 - 1003 MHz)
Level Control	Manual (MGC) / Automatic (AGC) Auto set-up feature

USER INTERFACE

Front Panel	
Bi-state Status LED	Normal = Green, Alarm = Red
Module Selection Indicator	Yellow LED
RF Attenuation Adjustment	

Monitor Point	
Laser RF Drive Monitor	
Return Loss	> 16 dB
Connector Type	Female F
Level	-20 ± 1 dB below input

NETWATCH™ ELEMENT MANAGEMENT SYSTEM

HEM Interface RS-485, RS-232C connectors (in HLP 4200)

Carrier Externally generated

POWER REQUIREMENTS

Nominal +24 VDC, supplied by HLP 4200 bus

Consumption 22 Watts maximum

ENVIRONMENTAL

Operating Temperature Range 0° to 50° C
32° to 122° F

Storage Temperature Range -40° to 70° C
-40° to 158° F

Relative Humidity Maximum 85% non-condensing

Software over temperature laser protection

PHYSICAL

Dimensions (WxHxD) 1.3" x 4.4" x 12.7"
3.3cm x 11.2cm x 32.2cm

Weight 2.1 lbs / 0.95 kg

Mounting HLP 4200 platform; via HMC module carrier

Optical connector type¹¹ SC/APC

RF connector type Standard F, RG-59 cable type (accepts 0.64-0.8 mm center conductor diameter)

Notes:

1. Channel loading: 78 unmodulated System M (NTSC) channels 55-550 MHz with 75 QAM256 (550-1003MHz) channels at -6 dBc relative to the analog carriers.
2. Pre-FEC BER maximum 1x10⁻⁶.
3. Eight, six, and four-wavelength system performance specifications include specified fiber, wavelength multiplexer and de-multiplexer, and 0 dBm optical power into NRM3111 receiver.
4. Two-wavelength system performance specifications include 30km of fiber, wavelength multiplexer and de-multiplexer, and -1.5 dBm optical power into NRM3111 receiver.
5. Maximum launch power per wavelength into the fiber: 4 wavelengths (9 dBm), 6 wavelengths (7dBm), 8 wavelengths (6 dBm).
6. For operation over entire temperature range subtract 0.5 dB from CNR.
7. Minimum C/CTB is 67 dBc over the full operating temperature range.
8. Minimum C/CSO is 58 dBc over the full operating temperature range and worst case polarization state. C/CSO is specified for in-band beats only.
9. Analog content on each wavelength must be identical with delay less than 100 meter or crosstalk impairment will result.
10. 12 ± 1dBm worst case due to measurement variation.
11. SC/APC is the connector type recommended by Harmonic. Other connector types are available upon request.